

HONG KONG EXAMINATIONS AND ASSESSMENT AUTHORITY
HONG KONG DIPLOMA OF SECONDARY EDUCATION EXAMINATION

COMBINED SCIENCE — BIOLOGY

(Sample Paper)

Time allowed: 1 hour 40 minutes

This paper must be answered in English.

GENERAL INSTRUCTIONS

1. There are **TWO** sections, A and B, in this Paper. Section A carries 24 marks and Section B carries 56 marks. You are advised to finish Section A in about 25 minutes.
2. Section A consists of multiple-choice questions in this question book. Section B contains conventional questions printed separately in Question-Answer Book B.
3. Answers to Section A should be marked on the Multiple-choice Answer Sheet while answers to Section B should be written in the spaces provided in Question-Answer Book B. **The Answer Sheet for Section A and the Question-Answer Book for Section B must be handed in separately at the end of the examination.**

SECTION A (MULTIPLE-CHOICE QUESTIONS)

INSTRUCTIONS FOR SECTION A

1. Read the instructions on the Answer Sheet carefully. Stick a barcode label and insert the information required in the spaces provided.
2. When told to open this book, you should check that all the questions are there. Look for the words '**END OF SECTION A**' after the last question.
3. All questions carry equal marks.
4. **ANSWER ALL QUESTIONS.** You should use an HB pencil to mark all your answers on the Answer Sheet. Wrong marks must be completely erased.
5. You should mark only **ONE** answer for each question. If you mark more than one answer, you will receive **NO MARKS** for that question.
6. No marks will be deducted for wrong answers.

There are 24 questions in this section.

The diagrams in this section are NOT necessarily drawn to scale.

Directions: Questions 1 and 2 refer to the electron micrographs and the table below. The electron micrographs show two sub-cellular structures, P and Q, of a eukaryotic cell, while the table shows the relative abundance of these two structures in four cell types in the human body:

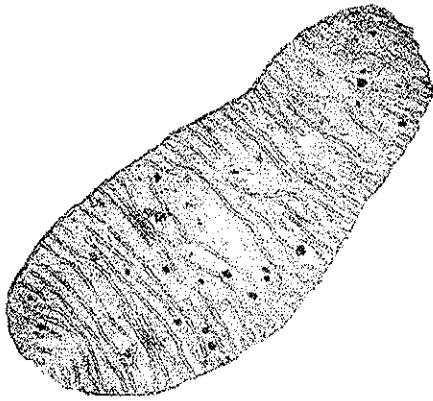

P

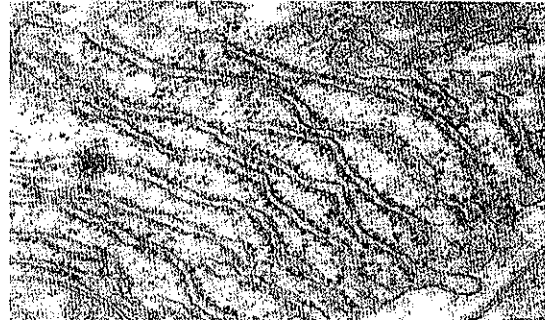

Q

Cell type	Structure P	Structure Q
1	++++	+++
2	++++	+
3	+	+
4	-	-

Key: number of '+' represents the relative abundance of the structure
 '-' represents absence of the structure

1. The relative abundance of structures P and Q in the epithelial cells of the air sacs of the lungs is most likely to be similar to that of
 - A. cell type 1.
 - B. cell type 2.
 - C. cell type 3.
 - D. cell type 4.

2. Which of the following can be found in structure P?
 - (1) ATP
 - (2) enzymes
 - (3) glycogen
 - A. (1) only
 - B. (1) and (2) only
 - C. (2) and (3) only
 - D. (1), (2) and (3)

3. The diagram below shows the fluid mosaic model of the cell membrane:

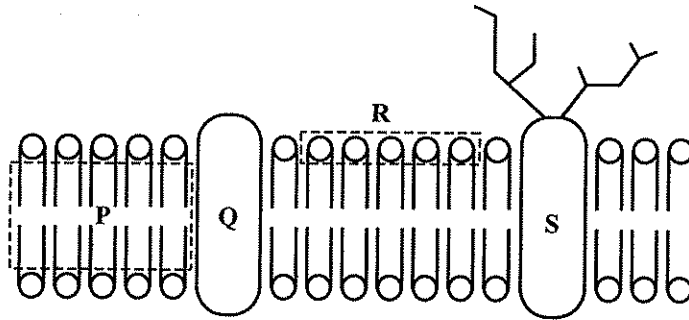

Which labelled part would restrict the movement of ions across the membrane?

- A. P
 - B. Q
 - C. R
 - D. S
4. The diagram below shows the lengths of three fresh potato cylinders before and after they were immersed in three sucrose solutions of different concentrations for one hour:

	Solution X	Solution Y	Solution Z
Before immersion	<input type="text"/>	<input type="text"/>	<input type="text"/>
After immersion	<input type="text"/>	<input type="text"/>	<input type="text"/>

When arranged from the lowest to the highest water potential, the sequence of the three solutions would be

- A. X, Z, Y.
 - B. Y, X, Z.
 - C. Y, Z, X.
 - D. Z, Y, X.
5. Which of the following are made up of proteins?
- (1) finger nails
 - (2) chromosomes
 - (3) amylase
- A. (1) and (2) only
 - B. (1) and (3) only
 - C. (2) and (3) only
 - D. (1), (2) and (3)

6. The graph below shows the exchange of carbon dioxide between a green plant and the atmosphere under different light intensities:

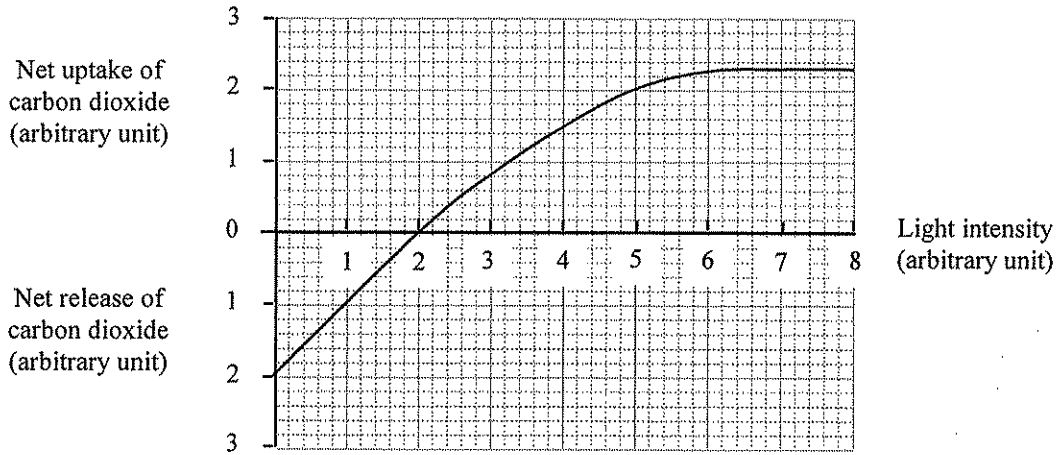

Which of the following can be deduced from the graph?

- (1) At 1 unit of light intensity, only respiration occurs.
 - (2) At 2 units of light intensity, no net photosynthesis occurs.
 - (3) At 7 units of light intensity, the rate of photosynthesis is higher than the rate of respiration.
- A. (1) and (2) only
 - B. (1) and (3) only
 - C. (2) and (3) only
 - D. (1), (2) and (3)

Directions: Questions 7 and 8 refer to an investigation to study the effect of diet on the performance of athletes. Three groups of athletes were each fed on a different diet for three days. The concentration of glycogen in their leg muscles was then measured. The athletes then exercised on a cycling machine at maximum level until they were exhausted. The results of the investigation are shown in the bar chart below:

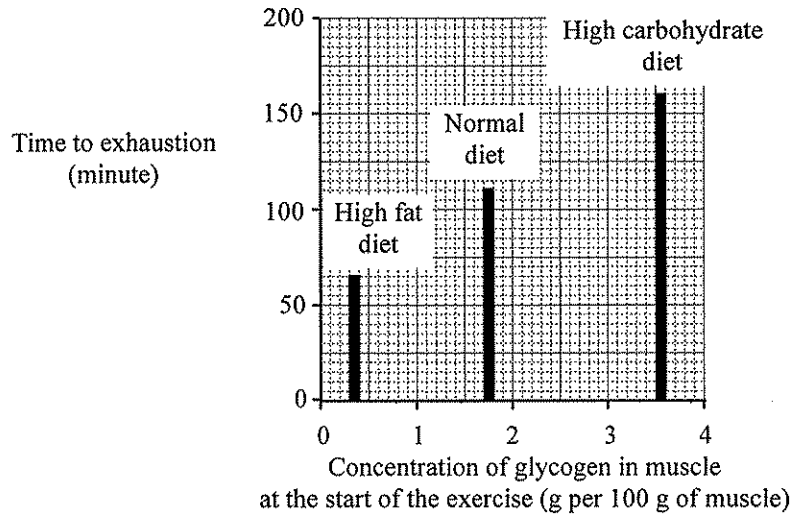

7. In order to make a valid comparison of the investigation results, the amount of proteins, vitamins and minerals in the diets have to be the same. Apart from these substances, what other parameter of the diets has to be identical?
- mass of the food intake
 - water content of the diet
 - energy content of the diet
 - proportion of dietary fibre in the diet
8. With reference to the bar chart, what conclusion can be drawn from the results of the investigation?
- A high-fat diet has a higher energy content than a high-carbohydrate diet.
 - The amount of fat stored in the leg muscles is smaller than the amount of glycogen stored.
 - The leg muscles undergo anaerobic respiration more readily when the athletes have a high-fat diet.
 - The more the glycogen stored, the longer the athlete can carry out vigorous exercise.
9. Which of the following secretions contain digestive enzymes and are alkaline?
- bile and saliva
 - saliva and gastric juice
 - bile and pancreatic juice
 - pancreatic juice and intestinal juice

Directions: Questions 10 and 11 refer to the diagram below, which shows a section of the heart:

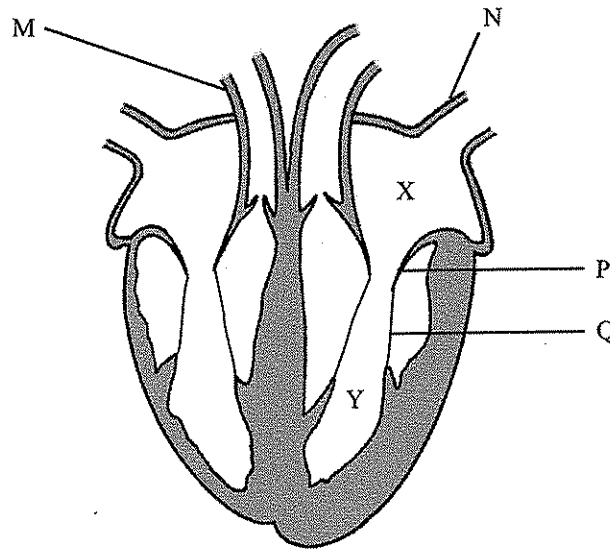

10. Which of the following comparisons of blood vessels M and N is correct?

	<i>Blood vessel M</i>	<i>Blood vessel N</i>
A.	thicker wall	thinner wall
B.	carbon dioxide present	carbon dioxide absent
C.	lower blood pressure	higher blood pressure
D.	lower urea content	higher urea content

11. Which of the following causes the closure of structure P?

- A. increase in tension of structure Q
- B. decrease in tension of structure Q
- C. decrease in pressure of chamber X
- D. increase in pressure of chamber Y

Directions: Questions 12 to 14 refers to the photomicrograph below which shows a section of the human lung:

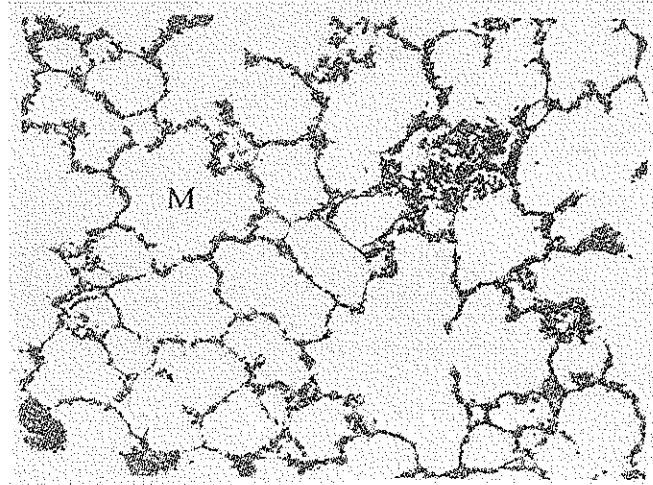

12. Which of the following features allow structures M to adapt to their function?

- (1) folded surface
- (2) thin and ciliated wall
- (3) rich supply of blood capillaries

- A. (1) and (2) only
- B. (1) and (3) only
- C. (2) and (3) only
- D. (1), (2) and (3)

13. The air in structure M consists mostly of

- A. nitrogen.
- B. oxygen.
- C. water vapour.
- D. carbon dioxide.

14. What is the long-term effect of cigarette smoking on structure M?

- A. The size of structure M decreases.
- B. The number of structure M decreases.
- C. The wall of structure M becomes more folded.
- D. The lumen of structure M becomes filled with blood.

15. Of the following groups of people, which group may have the highest risk of liver cancer?
- A. people suffering from alcoholism
 - B. people suffering from diabetes
 - C. people with smoking habits
 - D. people with weight problems

Directions: Questions 16 and 17 refer to the diagram below which shows the distribution of a type of light-sensitive cells on the surface of the retina:

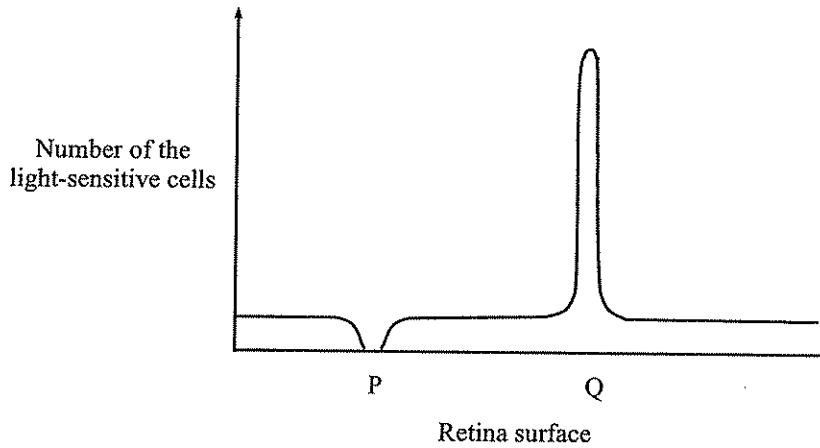

16. Which of the following correctly identifies the type of light-sensitive cells and region Q?

	<i>Type of light-sensitive cells</i>	<i>Region Q</i>
A.	rods	blind spot
B.	rods	yellow spot
C.	cones	blind spot
D.	cones	yellow spot

17. Which of the following will occur when light is focussed on region P?

- A. no image will be formed
- B. no vision will be generated
- C. only black and white vision will be generated
- D. colour vision will be generated

18. What is the role of the cerebrum and cerebellum when a person is swimming?

	<i>Cerebrum</i>	<i>Cerebellum</i>
A.	controls muscle contraction	coordinates muscular actions
B.	controls muscle contraction	regulates heart beat
C.	coordinates muscular actions	controls muscle contraction
D.	regulates heart beat	coordinates muscular actions

19. Which of the following is an example of primary succession?

- A. succession occurring on an abandoned farmland
- B. succession after a volcanic eruption
- C. succession after deforestation
- D. succession after a flood

Directions: Questions 20 to 22 refer to the diagram below, which shows the flow of energy in an ecosystem. W, X and Y represent different trophic levels and Z represents another group of organisms in the ecosystem.

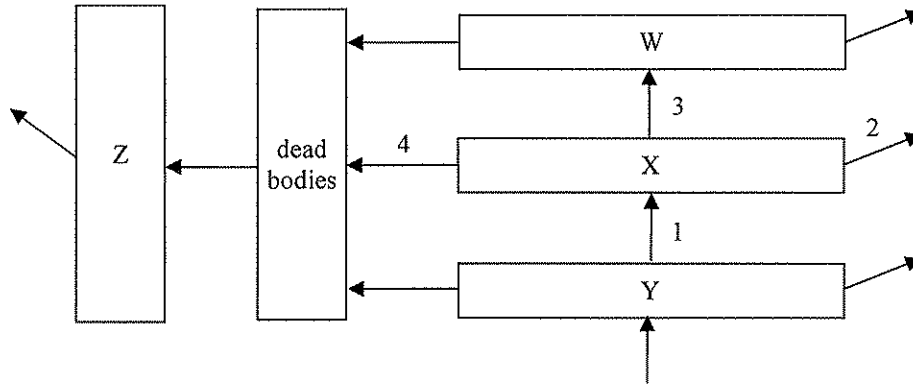

Key: \longrightarrow direction of energy flow

20. Organisms Z are

- A. predators.
- B. pathogens.
- C. parasites.
- D. decomposers.

21. Energy is lost from the ecosystem through process 2. What is this process?

- A. excretion
- B. respiration
- C. transpiration
- D. decomposition

22. With reference to trophic level X, the largest amount of energy flow occurs in

- A. 1.
- B. 2.
- C. 3.
- D. 4.

23. The chance of giving birth to a boy to that of a girl is 1:1. This is because
- (1) each egg is fertilized by one sperm only.
 - (2) the fertilization of eggs and sperms is random.
 - (3) sperms carrying different sex chromosomes are produced in equal proportions.
- A. (2) only
 - B. (1) and (3) only
 - C. (2) and (3) only
 - D. (1), (2) and (3)
24. Which of the following diseases *cannot* be prevented by good personal hygiene?
- A. cholera
 - B. haemophilia
 - C. tuberculosis
 - D. athlete's foot

END OF SECTION A

Go on to Question-Answer Book B for questions on Section B

B

HONG KONG EXAMINATIONS AND ASSESSMENT AUTHORITY
HONG KONG DIPLOMA OF SECONDARY EDUCATION EXAMINATION

COMBINED SCIENCE — BIOLOGY
(Sample Paper)

SECTION B : Question-Answer Book B

This paper must be answered in English.

INSTRUCTIONS

- (1) Write your Candidate Number in the space provided on Page 1.
- (2) Stick barcode labels in the spaces provided on Pages 1, 3, 5 and 7.
- (3) Refer to the general instructions on the cover of the Question Book for Section A.
- (4) The questions in this Question-Answer Book carry 56 marks. Answer **ALL** questions..
- (5) Write your answers to Section B in the spaces provided in this Question-Answer Book. Do not write in the margins. Answers written in the margins will not be marked.
- (6) Supplementary answer sheets will be provided on request. Write your candidate number, fill in the question number and stick a barcode label on each sheet. Tie them loosely but securely with a string **INSIDE** this Question-Answer Book.
- (7) Present your answers in paragraphs wherever appropriate.
- (8) The diagrams in this section are **NOT** necessarily drawn to scale.

Please stick the barcode label here.

Candidate Number

	Marker's Use Only	Examiner's Use Only
	Marker No.	Examiner No.
Question No.	Marks	Marks
1		
2		
3		
4		
5		
6		
7		
8		
9		
Total		

SECTION B

Answer **ALL** questions. Put your answers in the spaces provided.

- 1. For each of the biological processes listed in column 1, select **one** type of membrane transport mechanisms listed in column 2 that accounts for the process. Put the appropriate letter in the space provided. (2 marks)

Column 1

Haemolysis of red blood cells when placed in 0.1% sodium chloride solution

.....

Uptake of oxygen into red blood cells

.....

Column 2

- A. active transport
- B. diffusion
- C. osmosis
- D. phagocytosis

- 2. The photograph below shows a kind of dolphin that can be found in the coastal areas of Hong Kong:

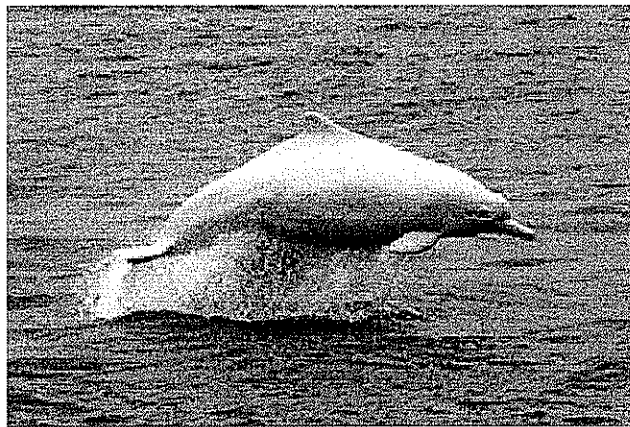

- (a) Based on **two** features of the dolphin observed in the photograph, state how each feature enables it to adapt to this habitat. (2 marks)

.....

.....

.....

Answers written in the margins will not be marked.

Answers written in the margins will not be marked.

Answers written in the margins will not be marked.

Please stick the barcode label here.

(b) This dolphin is a protected species in Hong Kong. State how *two* human activities might pose threats to its survival in Hong Kong waters. (2 marks)

.....

.....

.....

.....

(c) According to the modern classification systems, dolphin and goldfish belong to the same group but different sub-groups. State *one* structural difference between these two animals that forms the basis for classifying them into different sub-groups. (1 mark)

.....

.....

Answers written in the margins will not be marked.

Answers written in the margins will not be marked.

3. The photomicrographs below show changes in a cell when it undergoes a certain type of cell division:

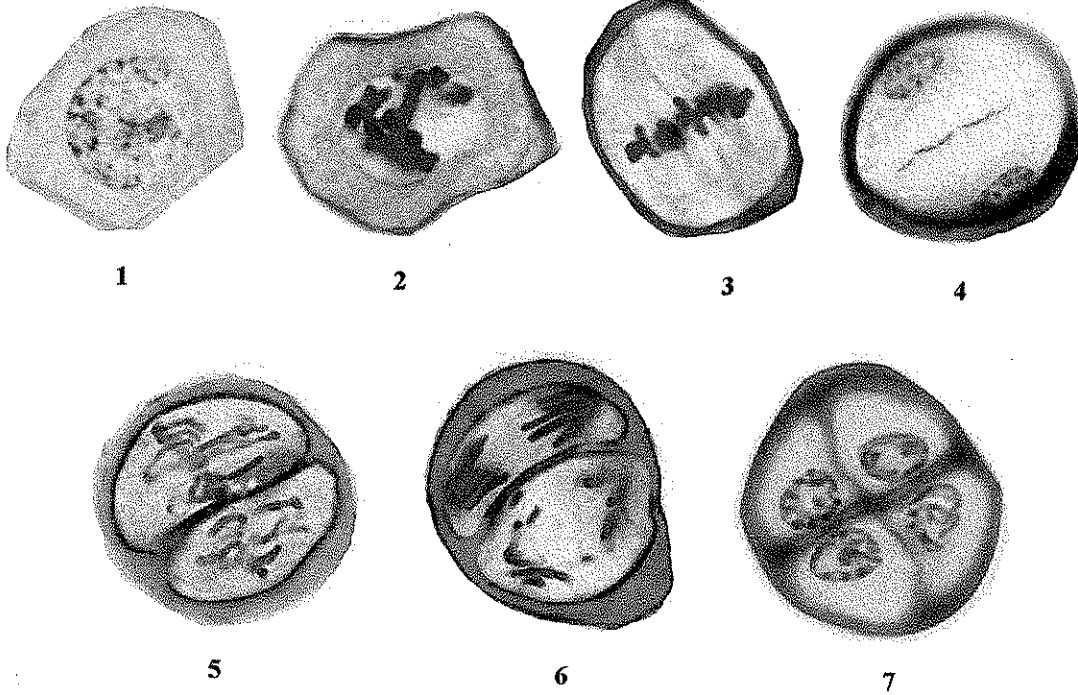

(a) State *two* processes occurring in stage 1 which prepare the cell for this type of cell division. (2 marks)

.....

.....

.....

.....

Answers written in the margins will not be marked.

Answers written in the margins will not be marked.

Please stick the barcode label here.

(b) Explain the significance of the behaviour of chromosomes in stage 3 to the outcomes of this type of cell division. (4 marks)

.....

.....

.....

.....

.....

.....

.....

.....

Answers written in the margins will not be marked.

Answers written in the margins will not be marked.

Answers written in the margins will not be marked.

4. During the course of history, scientists have developed different systems for classifying the diverse range of living organisms based on different criteria. The table below lists some of the different classification systems developed in the past centuries:

Scientist	Linnaeus	Chatton	Copeland	Whittaker	Woese et al.	Woese et al.
Year of proposal	1735	1937	1956	1969	1977	1990
System	2 kingdoms	2 empires	4 kingdoms	5 kingdoms	6 kingdoms	3 domains
Group	(not treated)	Prokaryota	Prokaryota	Prokaryota	Eubacteria	Bacteria
					Archaeobacteria	Archaea
	Vegetabilia	Eukaryota	Protoctista	Protista	Protista	Eukarya
			Plantae	Fungi	Fungi	
				Plantae	Plantae	
Animalia	Animalia		Animalia	Animalia		

(a) In 1937, Chatton classified all living organisms into two empires. List *two* major differences between these two empires. (2 marks)

.....

.....

.....

(b) Complete the key below, which serves to classify eukaryotic organisms into four kingdoms as proposed by Whittaker: (3 marks)

1a Predominantly unicellular.....Protista
 1b Multicellular.....2

2a

2b

3a

3b

Answers written in the margins will not be marked.

Answers written in the margins will not be marked.

Answers written in the margins will not be marked.

Please stick the barcode label here.

(c) Suggest *two* reasons why the classification system of organisms keeps changing over time. (2 marks)

.....

.....

.....

.....

Answers written in the margins will not be marked.

Answers written in the margins will not be marked.

Answers written in the margins will not be marked.

5. The graph below shows the oxygen content of blood in the aorta and that in the vena cava, and the oxygen uptake of a person performing exercise of different intensities. The intensity of exercise is expressed as the energy requirement of the exercise.

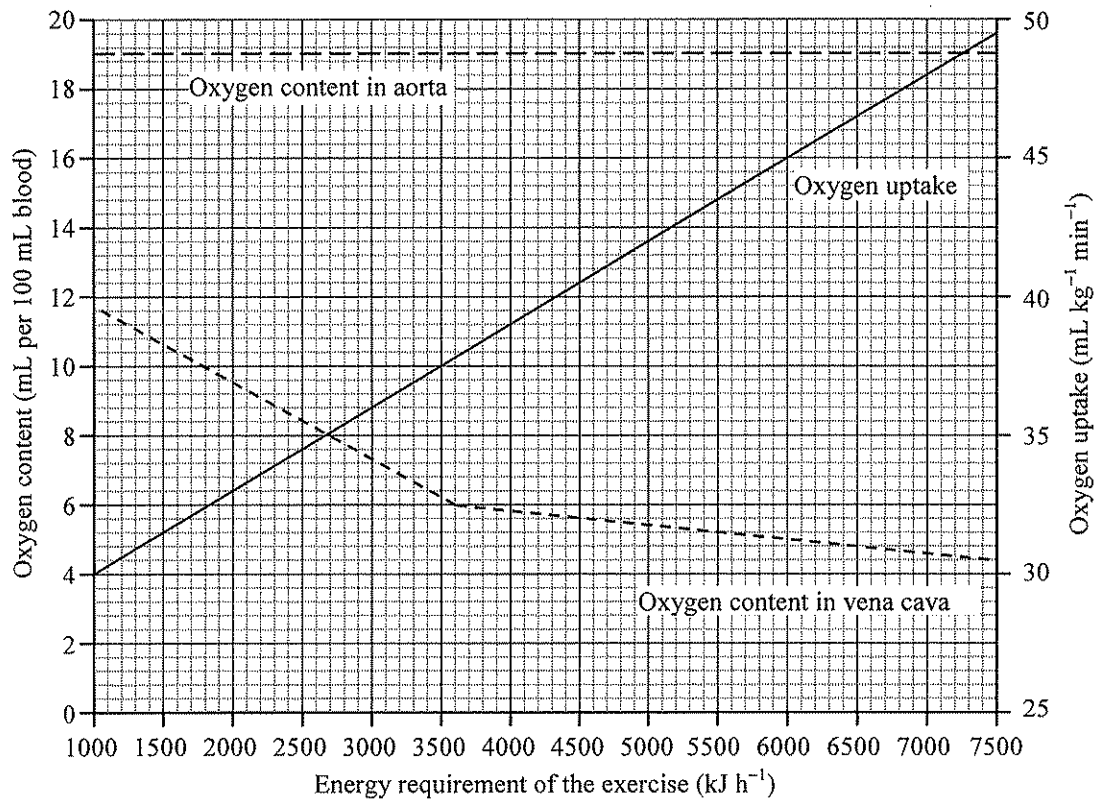

- (a) The energy requirements for running and leisurely cycling are 3600 kJ h⁻¹ and 1800 kJ h⁻¹ respectively. Calculate the difference in the blood oxygen content between the aorta and the vena cava for each type of exercise. (2 marks)

Running : _____

Cycling : _____

Answers written in the margins will not be marked.

Answers written in the margins will not be marked.

(b) How does the difference in blood oxygen content between the two blood vessels change with the intensity of exercise? Account for this change. (4 marks)

.....

.....

.....

.....

.....

.....

.....

.....

Answers written in the margins will not be marked.

Answers written in the margins will not be marked.

Answers written in the margins will not be marked.

6. Mr and Mrs Chan gave birth to a pair of twins, Anne and Jane. The table below lists some characters shown by the twins:

Character	Anne	Jane
Body mass (at the age of 6)	20 kg	21 kg
Colour vision	normal	normal
Blood group	O	AB
IQ	110	105

(a) State the type of twins they belong to. Explain how you arrive at your answer. (3 marks)

.....

.....

.....

.....

.....

.....

Answers written in the margins will not be marked.

Answers written in the margins will not be marked.

Answers written in the margins will not be marked.

(b) Deduce the blood group(s) of their parents. Explain your deduction. (6 marks)

(Use the symbols I^A , I^B and i to represent the alleles for determining the inheritance of blood groups.)

.....

.....

.....

.....

.....

.....

.....

.....

.....

.....

.....

.....

.....

.....

.....

.....

.....

.....

.....

.....

.....

Answers written in the margins will not be marked.

Answers written in the margins will not be marked.

Answers written in the margins will not be marked.

7. A biological washing powder claims to contain the enzyme lipase which can help the removal of fat stains. To study the effectiveness of this biological washing powder, three identical skirts with identical fat stains were washed with the washing powder solutions of the same concentration but at different water temperatures. The investigation and its results are outlined below:

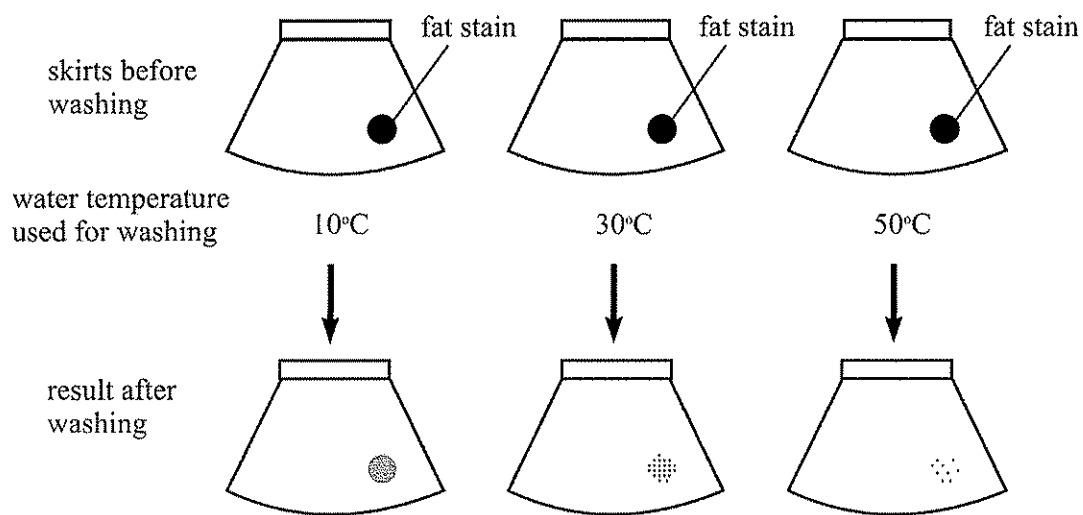

(N.B. The investigation was repeated at the three temperatures, but no washing powder was used. The fat stains on all three skirts remained unchanged.)

(a) What conclusion can be drawn from the results of this investigation? (1 mark)

Answers written in the margins will not be marked.

Answers written in the margins will not be marked.

(b) A student queried whether or not biological washing powder is more effective than ordinary (non-biological) washing powder in removing fat stains. If you were the student, describe how you would carry out an investigation to find out which washing powder is more effective. (5 marks)

.....

.....

.....

.....

.....

.....

.....

.....

.....

.....

.....

Answers written in the margins will not be marked.

Answers written in the margins will not be marked.

Answers written in the margins will not be marked.

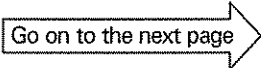

8. The graph below shows changes in the rate of secretion of two pancreatic hormones, A and B, at different blood glucose levels in humans:

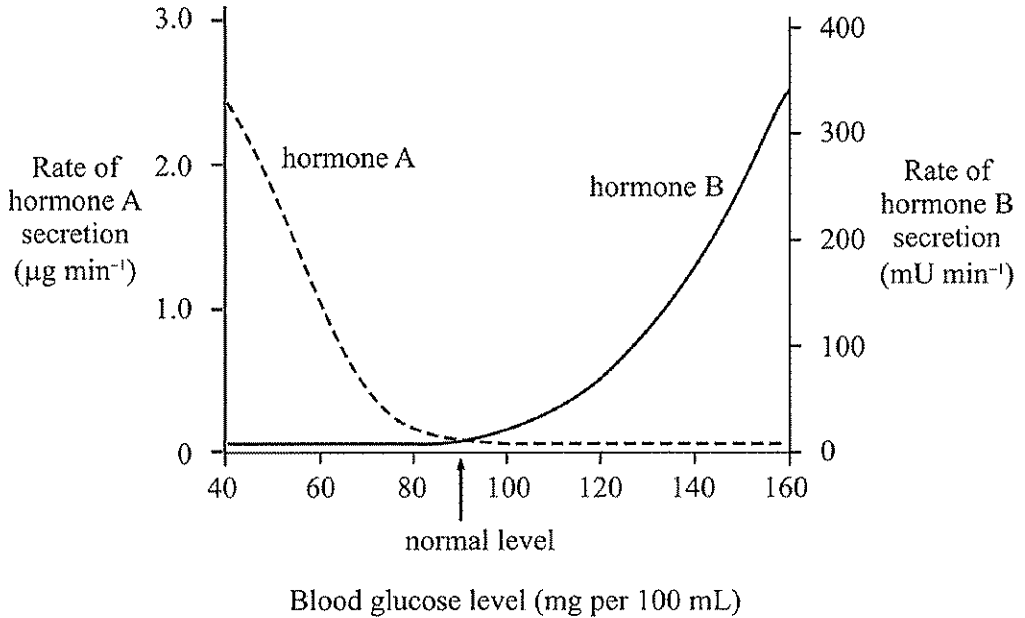

(a) Which hormone will play an active role in the homeostatic control of blood glucose level when it drops from the normal level to 40 mg per 100 mL? Give evidence from the graph to support your answer. (3 marks)

.....

.....

.....

.....

.....

(b) Name hormone A and state how this hormone contributes to the homeostatic control of blood glucose level. (3 marks)

.....

.....

.....

.....

.....

Answers written in the margins will not be marked.

Answers written in the margins will not be marked.

Answers written in the margins will not be marked.

